

High Efficient Fanless Touch Panel PCs

Value-oriented and entry level touch Panel PCs for hospitality environments with AMD® fanless thermal technology featured.

SolidPPC 50 Series



FEATURES

- Built-in AMD® low power consumption and high performance technology.
- Fanless all-in-one Industrial panel PC grade products fits in any critical environments.
- 8.4" / 12" / 15" TFT LCD with 5-wire resistive touch panel for friendly interface.
- Ultra compact design with VESA mounting for smart space management at anyplace.

SolidPPC 50 Series Features

Fanless design for long-term daily operation

All-in-one highly efficient touch Panel PC



EBN SolidPPC 50 series is an integrated all-in-one fanless touch panel PC that delivers efficient performance for daily operation with cost-effective concepts. SolidPPC 50 series builds up with AMD® Geode LX-800 500MHz CPU and supports system memory upto 1GB to offer a stable performance to deal with the great quantity operation data. Combining with 5-wire restive touch screen, it delivers a friendly interactive platform for operation and speed up the customer service process in anyplace application.

Thanks for the AMD® low power consumption technology, SolidPPC 50 fanless design is ideal for low-noise working environment and less movable parts translates to greater reliability and durability. While working time, SolidPPC 50 series is always silence in the critical application. Considering about the environment friendly concept, SolidPPC 50 is housed by the aluminum materials, it provides the best efficiency thermal elimination to help SolidPPC 50 series working dynamic and more reliable.



Audio

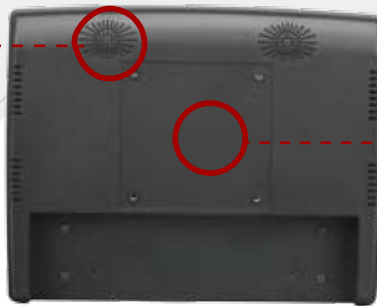

SolidPPC 508
8.4" TFT Panel PC



Support VESA mount



Smart interactive platform application in Japan



Fanless, silent, reliable and compact size design

Flexible configurations for further integration

EBN's SolidPPC 50 series delivers the stable high performance in order to handle accesses from users, it supports one 10/100 Base-T LAN port, 3 x RS-232 connectors and 2 x USB 2.0 ports equipped allow users to set up the system as their particular needs without any hardware limitation, and fan-less thermal solution adopted makes cost and time of maintenance to be reduced substantially.



Your smarter interactive platform

There are more than 5,000 SolidPPC 50 series running and serving customers in every branch of the leading sushi chain restaurant over all Japan. Customers place their orders just by touching the screen deliver directly to the kitchen and customers can view the latest commercials showed on the LCD screen. Customer of all ages enjoying in using the smart ordering platform and are satisfied with the fast service and the fancy interface. The smart ordering platform also helps this chain restaurant to improve the service process and raise its popularity, of course, revenues are raised, too. With the above benefits, EBN's SolidPPC 50 is your best investment for interactive platform and brings the highest ROI for you.

Touch



Support VESA mount



SolidPPC 512 / SolidPPC 515
12.1" / 15" TFT Panel PC



Pole mountable



Optional MSR / Dallas
Key Reader



I/O interface

Specifications

Model Name	SolidPPC 508	SolidPPC 512	SolidPPC 515	
Main Board	CPU	AMD® Geode™ LX-800 (500MHz)		
	Core Logic	AMD® Geode™ LX-800 + CS5536		
	System Memory	SO-DIMM, DDR400, 128MB, up to 1GB		
	OS Support	Windows® XP / XPe, WEPOS, WinCE*, Linux*		
Display	TFT LCD Size	8.4"	12.1"	15"
	Brightness	220 nits	200 nits	250 nits
	Resolution	800 x 600	800 x 600	1024 x 768
	Touch Screen	5-wire Resistive Type		
Storage Device	DOM	1 x IDE, 2.0mm 44pin		
	HDD	N/A	1 x 2.5" HDD Drive Bay	1 x 2.5" HDD Drive Bay
	Compact Flash	1 x Slot Compact Flash Type II		
I/O Ports	Serial	3 x RS-232 COM 1 / 2 : DB-9, Pin 9 w/ RI / 5V / 12V Selectable COM 3 : 15-Pin Header		
	USB	2 x USB 2.0		
	PS/2	15-Pin Header		
	LAN	1 x RJ-45, 10/100 Base-T, supports wake on LAN		
	Cash Drawer	1 x RJ-11 (Power Pin 12V)		
	Audio	Audio AC' 97 2.0 Compliant, 2W Speaker x 2		
	Wall Mount	Support VESA Mount		
Others	Power Input	External adapter, 80W, 12VDC input		
	Color	Black		
	Material	Plastic		
	Compliance	FCC / CE / WEEE / RoHS		
	Weight	1.2 kgs	2.6 kgs	3.9 kgs
	Dimension	234Wx42Dx185H(mm)	313W x46.5Dx256H(mm)	370Wx50.5Dx310H(mm)
	Operating Temperature	5°C ~ 40°C		
	Storage Temperature	-20°C ~ 60°C		
	Humidity	20% - 85% RH, non-condensing		

* Please contact supplier for detail information.

SolidPPC 515

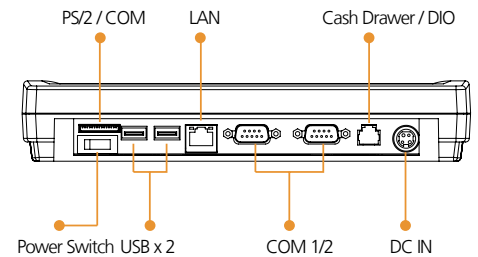
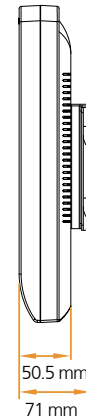
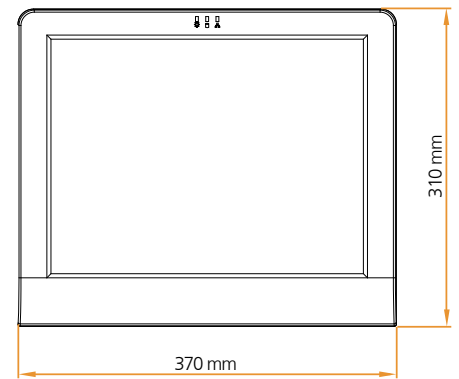

Ordering information

Main Unit

Part No.	Description
PPC50A-8B-LX800	Fanless SolidPPC 508 w/ 8.4" TFT LCD w/ AMD® LX800 CPU
PPC50A-2B-LX800	Fanless SolidPPC 512 w/ 12.1" TFT LCD w/ AMD® LX800 CPU
PPC50A-5B-LX800	Fanless SolidPPC 515 w/ 15" TFT LCD w/ AMD® LX800 CPU
PPC50B-2B-LX800	Fanless SolidPPC 512 w/ 12.1" TFT LCD w/ AMD® LX800 CPU
PPC50B-5B-LX800	Fanless SolidPPC 515 w/ 15" TFT LCD w/ AMD® LX800 CPU

Part No. Description

20600033	Compact Flash: 8GB
20300005	Memory: DDR400, 128MB, 200Pin SO-DIMM, non-ECC
20300006	Memory: DDR400, 256MB, 200Pin SO-DIMM, non-ECC
20300007	Memory: DDR400, 512MB, 200Pin SO-DIMM, non-ECC
20300019	Memory: DDR400, 1GB, 200Pin SO-DIMM, non-ECC
20900001	OS License: Windows XP Professional, English Version
20900002	OS License: WEPOS, English Version

Specifications are subject to change without notice. Issue Date: 2009/05

Optional Accessories

Part No.	Description
A0400165	MSR: 2 Tracks, PS/2 Type
A0400127	MSR: 3 Tracks, PS/2 Type
A0400333	MSR: 2 Tracks, RS-232 Type
A0400205	MSR: 3 Tracks, RS-232 Type
A0400128	iButton & MSR: 3 Tracks, PS/2 Type
A0400129	iButton: PS/2 Type
20200020	HDD: IDE, 2.5", 80GB
20200023	HDD: SATA, 2.5", 160GB
20600001	Compact Flash: 128MB
20600002	Compact Flash: 256MB
20600018	Compact Flash: 512MB
20600005	Compact Flash: 1GB
20600023	Compact Flash: 2GB
20600024	Compact Flash: 4GB

EBN
EBN Technology Corp.

EBN Technology Corp.

10F, No. 90, Sec. 1, Sintai 5th Rd., Sijhih City,
Taipei County 221, Taiwan
TEL : +886-2-2696 9292
FAX : +886-2-2696 9393
E-mail : sales@ebn-pos.com
www.ebn-pos.com