

# Ideal Touch Fanless Touch Panel PC

Fanless Touch Panel PC powered by Intel® ATOM™ 1.6GHz CPU  
and featured variety I/O interface for industrial applications

## X-PPC 752



### FEATURES

- Built-in Intel® ATOM™ low power consumption and high performance solutions.
- Fanless all-in-one industrial Panel PC grade products fits in any critical environments.
- 15" TFT LCD with 5-wire resistive touch panel for friendly interface.
- Ultra compact design with VESA mounting for smart space management at anyplace.
- Front panel IP55 protection



Fanless, silent, reliable and compact size design



Rich configuration



Pole ARM moutable with VESA standard

## Specifications

|                       |                         |  |
|-----------------------|-------------------------|--|
| <b>Model Name</b>     | X-PPC 752               |  |
| <b>Main Board</b>     | CPU                     | Intel® Atom™ Processor N270 1.6GHz   |
|                       | Core Logic              | Intel 945GSE / ICH7-M  |
|                       | System Memory           | SO-DIMM DDR2, 128MB up to 2GB  |
|                       | OS Support              | Windows® XP / XPe, WEPOS, WinCE*, POSReady, Vista, Windows 7, Linux*   |
| <b>Display</b>        | TFT LCD Size            | 15"  |
|                       | Brightness              | 250 nits   |
|                       | Resolution              | 1024 x 768   |
|                       | Touch Screen            | 5 wire resistive type  |
| <b>Storage Device</b> | DOM                     | 1 x IDE  |
|                       | HDD                     | 1 x 2.5" HDD Drive Bay   |
|                       | Compact Flash           | 1 x slot compact flash typell  |
| <b>I/O Ports</b>      | Serial                  | 3 x RS-232<br>COM 1 : RS-232/422/485, DB-9, Pin9 w/ RI/5V/12V Selectable by BIOS<br>COM 2 / 5 : DB-9, Pin9 w/ RI/5V/12V Selectable by BIOS |
|                       | Parallel                | 1 x DB25   |
|                       | USB                     | 4 x USB 2.0  |
|                       | PS/2 Keyboard / Mouse   | 1 x Mini-DIN   |
|                       | LAN                     | 1 x Gigabit Ethernet by RJ-45, Support Wake on LAN   |
|                       | Cash Drawer             | 1 x RJ11 (12VDC)   |
|                       | Audio                   | 2W Speaker x 2   |
|                       | VGA                     | 1 x Internal pin header  |
|                       | Wall mount              | Support VESA Mount   |
|                       | Power Input             | External adapter, 80Watt, 12VDC input  |
| <b>Others</b>         | Color                   | Black  |
|                       | Material                | Plastic / Aluminum   |
|                       | EMC & Safety Compliance | FCC / CE / WEEE / RoHS / CCC / CB  |
|                       | Weight                  | 4.91 Kgs   |
|                       | Dimension               | 365W x 60D x 289H (mm)   |
|                       | Operating Temperature   | 0°C ~ 35°C   |
|                       | Storage Temperature     | -20°C ~ 60°C   |
|                       | Humidity                | 20% - 80% RH, non-condensing   |

\* Please contact supplier for detail information.

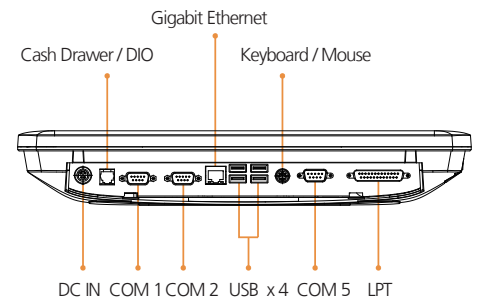
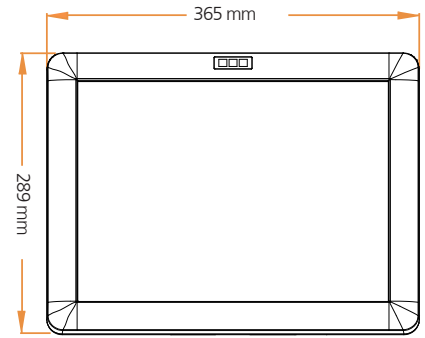

## Ordering information

### Main Unit

| Part No.       | Description   |
|----------------|---|
| XPCC72-5B-A16G | Fanless Touch Panel PC w/ 15" TFT LCD, Intel® ATOM™ N270 1.6GHz CPU |

### Optional Accessories

| Part No. | Description   |
|----------|---|
| Z1300059 | Customer display: LCM Attached, 20 columns x 2 lines, RS-232 Type |
| Z1300060 | Customer display: VFD Attached, 20 columns x 2 lines, RS-232 Type |
| Z0500002 | MSR-Front Type, 3 Tracks, PS/2 Type                               |
| Z0500003 | MSR-Side Type, 3 Tracks, PS/2 Type                                |
| Z0500004 | MSR-Side Type, 3 Tracks, PS/2 Type & Finger Print, USB Type       |
| Z0500005 | MSR-Side Type, 3 Tracks, PS/2 Type & i-Button, PS/2 Type          |
| Z0500006 | MSR-Side Type, 3 Tracks, PS/2 Type & RFID, USB Type               |
| A0400807 | Wireless LAN: IEEE 802.11 B/G, USB Type                           |
| 20600018 | Compact Flash: 512MB  |
| 20600005 | Compact Flash: 1GB  |
| 20600023 | Compact Flash: 2GB  |
| 20600024 | Compact Flash: 4GB  |
| 20600033 | Compact Flash: 8GB  |
| 20900001 | OS License: Windows XP Professional, English Version              |
| 20900002 | OS License: WEPOS, English Version                                |

| Part No. | Description  |
|----------|--|
| 20900021 | OS License: Windows Embedded POSReady, English Version |
| 20300021 | Memory: DDR2-667, 512MB, 200PIN, SO-DIMM               |
| 20300023 | Memory: DDR2-667, 1GB, 200PIN, SO-DIMM                 |
| 20300024 | Memory: DDR2-667, 2GB, 200PIN, SO-DIMM                 |
| 20200023 | 2.5" Slim Type HD: 160GB SATA Type                     |

Specifications are subject to change without notice. Issue Date: 2010/01

**EBN**  
EBN Technology Corp.

### EBN Technology Corp.

10F, No. 90, Sec. 1, Sintai 5th Rd., Sijhih City,  
Taipei County 221, Taiwan  
TEL : +886-2-2696 9292  
FAX : +886-2-2696 9393  
E-mail : sales@ebn-pos.com  
www.ebn-pos.com